

HIGH PERFORMANCE *PUMPS*

Designed for commercial and extra large domestic pools, Waterco high performance pumps provide the extra power needed to cope with ancillary systems like water features, infloor cleaning, vacuum cleaning and swim/spa jets.



Efficient Impeller and Diffuser Design

The pump's impeller and diffuser design maximizes the hydraulic output of the pump while minimizing turbulence. The pump's efficient hydraulic performance shortens run times and reduces energy consumption leading to lower operating costs.

Engineered Durability

The pump body is manufactured utilising state of the art engineering plastic moulding with a single piece strainer pot and volute for extra strength.

A high grade 316 stainless steel mechanical seal is incorporated for extra protection against corrosion. e.g. from chlorinated water, ozone, iodine, Baquacil, bromine and salt water.

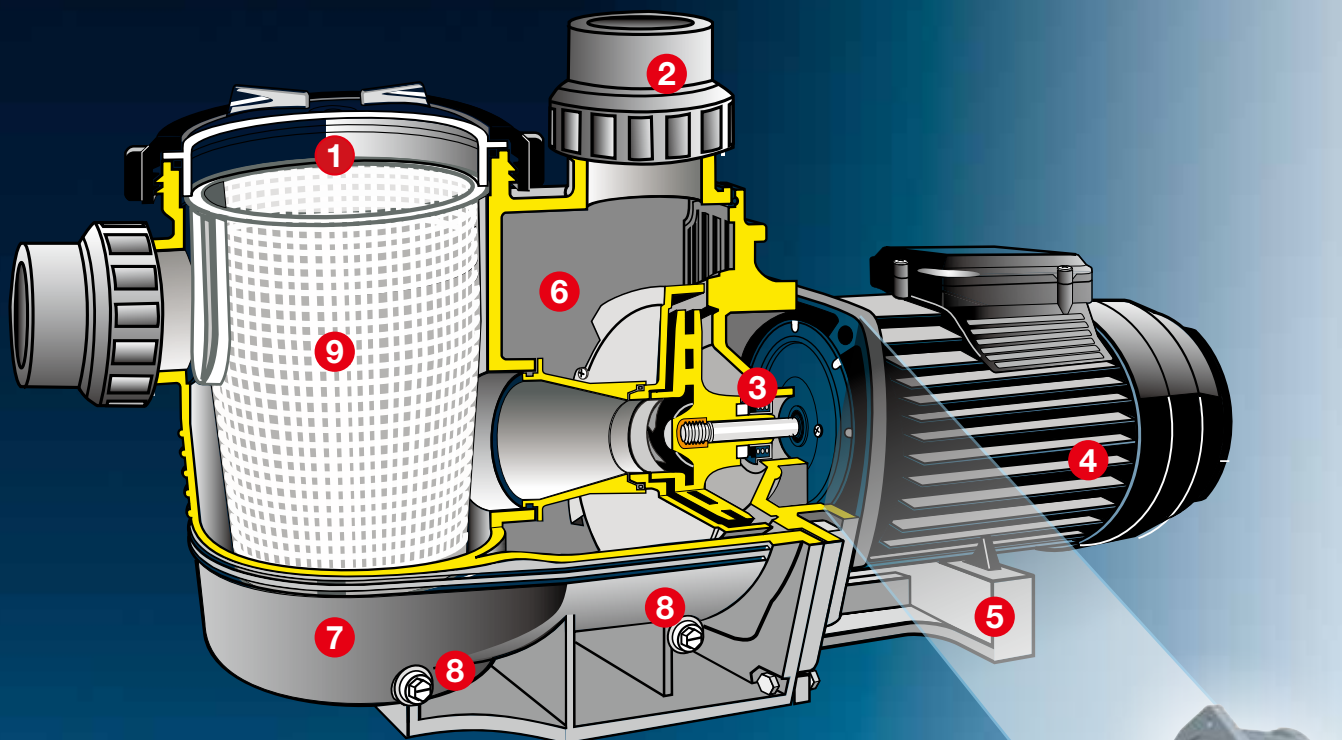

1. Clear basket lid.
2. Quick connect barrel unions for UPVC pipe.
3. High grade carbon/graphite mechanical seal with 316 stainless steel spring assembly.
4. High performance motor:
 - IP55 rating
 - Motor shaft 431 grade stainless steel.
 - Fan cooled.
 - Thermal overload protection
5. Stable support base.
6. Hydraulically efficient impeller and diffuser design.
7. Strong single piece glass filled thermoplastic pump body.
8. Drain plugs.
9. Extra large strainer basket – captures debris and protects the impeller.
10. Motor protection bracket protects the motor from a leaking mechanical seal

Motor Pump Protection Bracket

Situated between the pump wet end & the pump motor, a mechanical seal forms a seal around the motor shaft to prevent water from travelling along the motor's shaft.

The mechanical seal is the wearing part of any pool pump. A mechanical seal may leak water if the pump is ever run dry or simply be worn out. The "Motor Protection Bracket" adds a 60.5mm separation between the pump's wet end and its motor. It is designed to protect the pump motor by draining any leaks from a worn mechanical seal.

	Strainer basket size
Hydrostorm	2.1L
Hydrostorm Plus	2.25L
Hydrostar	6L

Hydrostorm

The Hydrostorm is designed to have all the extra power you need to cope with modern day swimming pool designs.



Flow Curves

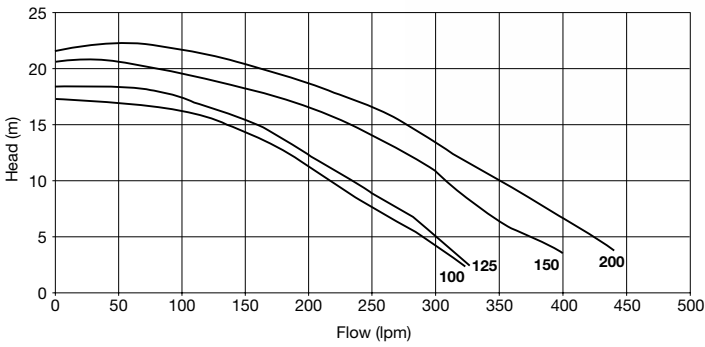

Sound Levels

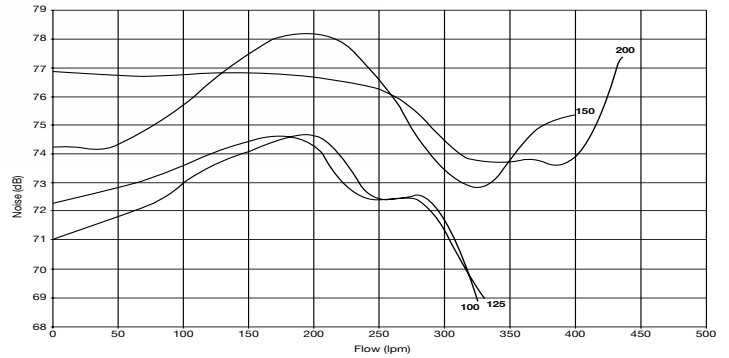

Technical specification

Model	Flow rate (lpm)		Nom. HP	kW	Amps	Phase	Total Length (mm)	Motor Frame (mm)	Inlet/Outlet
	8m	10m							
Hydrostorm 100	250	225	1	0.91	4.00	1	600	71	50mm ports x / 50mm unions
Hydrostorm 125	270	245	1.25	1.08	4.80	1	600	71	50mm ports x / 50mm unions
Hydrostorm 150	350	315	1.5	1.31	5.80	1	647	80	50mm ports x / 50mm unions
Hydrostorm 200	370	350	2	1.46	6.60	1	647	80	50mm ports x / 50mm unions

Phase	Volts	Cycle	RPM
1	220- 240	50	2860

Dimension

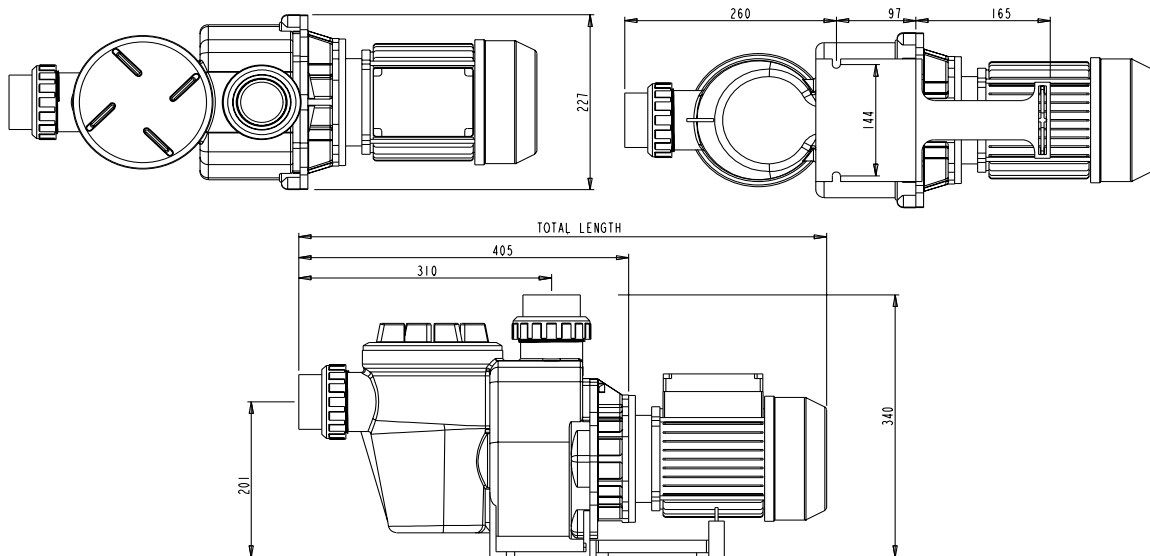

Hydrostorm Plus

The Hydrostorm plus has all the proven features of the Hydrostorm with the addition of an innovative lid & lock ring for easier maintenance and a larger strainer basket for increased capacity.



Flow Curves

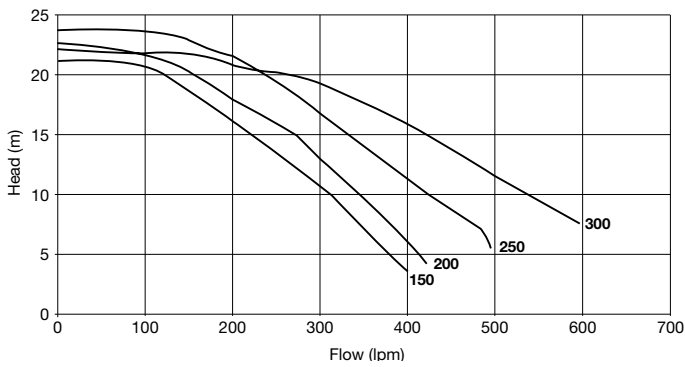

Sound Levels

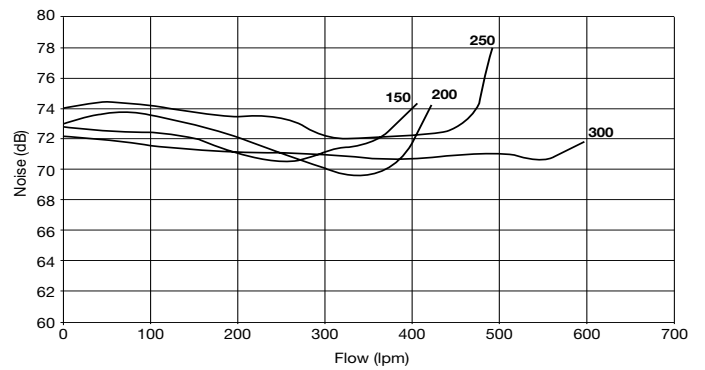

Technical specification

Model	Flow rate (lpm)		Nom. HP	kW	Amps	Phase	Total Length (mm)	Motor Frame (mm)	Inlet/Outlet
	8m	10m							
Hydrostorm Plus 150	350	325	1.5	1.40	5.8	1	678	80	50mm ports x / 50mm unions
Hydrostorm Plus 200	390	350	2	1.51	6.3	1	678	80	50mm ports x / 50mm unions
Hydrostorm Plus 250	470	440	2.5	1.85	7.8	1	678	80	65mm ports x / 50mm unions
Hydrostorm Plus 300	545	500	3	2.08	9.0*	1	730	90	65mm ports x / 50mm unions

*15 Amp Power Lead Plug

Phase	Volts	Cycle	RPM
1	220- 240	50	2860

Dimension

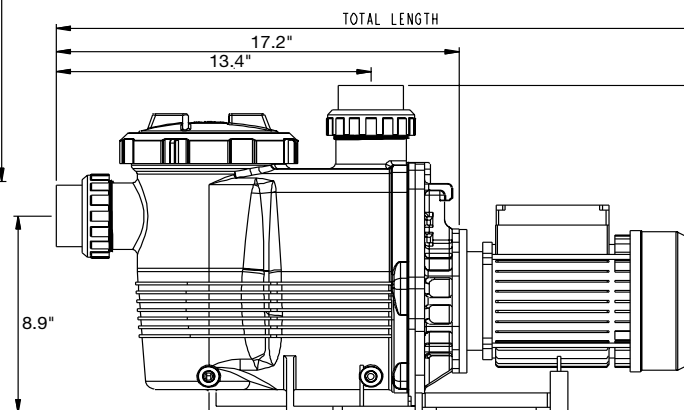
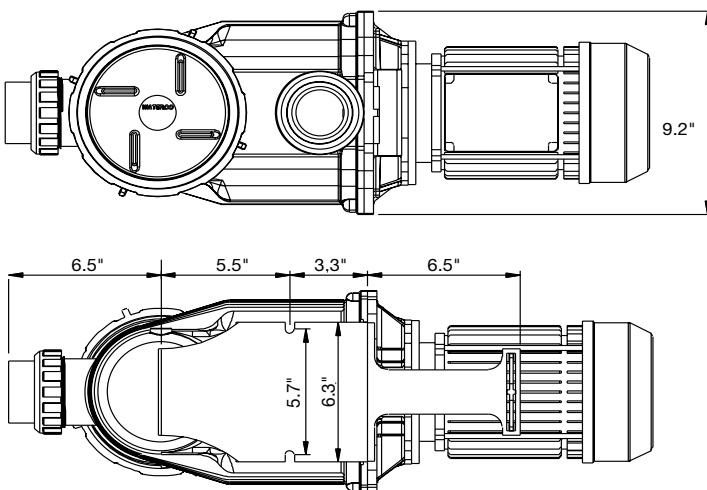

Hydrostar

Built with an innovative quarter lid & lock ring and extra large strainer basket, the Hydrostar is ideal for large domestic and commercial sized swimming pools.



Flow Curves

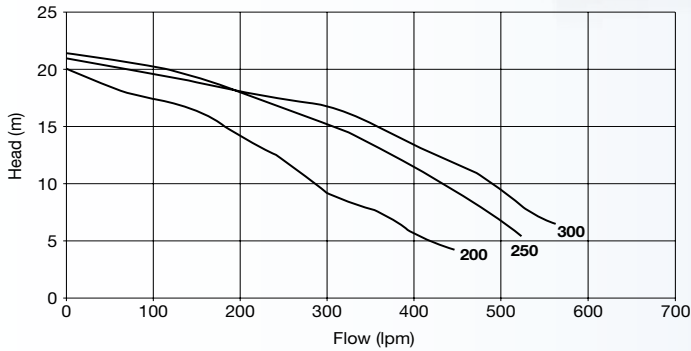

Sound Levels

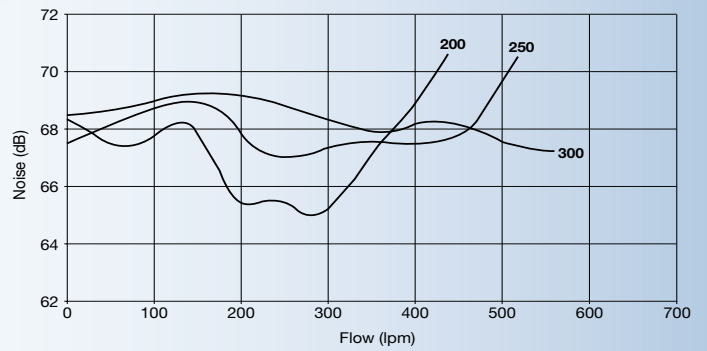

Technical specification

Model	Flow rate (lpm)		Nom. HP	kW	Amps	Phase	Total Length (mm)	Motor Frame (mm)	Inlet/Outlet
	8m	10m							
Hydrostar 200	370	330	2	1.46	6.5	1	771	80	65mm ports x / 50mm unions
Hydrostar 250	470	440	2.5	1.96	9.3	1	771	80	65mm ports x / 50mm unions
Hydrostar 300	530	480	3	2.33	10.9	1	792	90	65mm ports x / 50mm unions
Hydrostar 300	530	480	3	2.33	10.9	1	792	90	80mm ports x / 80mm unions
Hydrostar 200 (3 phase)	370	330	2	1.41	2.5	3	770	90	65mm ports x / 50mm unions
Hydrostar 250 (3 phase)	470	440	2.5	1.92	3.8	3	770	90	65mm ports x / 50mm unions
Hydrostar 300 (3 phase)	530	480	3	2.25	4.1	3	792	90	80mm ports x / 80mm unions

Phase	Volts	Cycle	RPM
1	220- 240	50	2860
3	380- 420	50	2860

Dimension

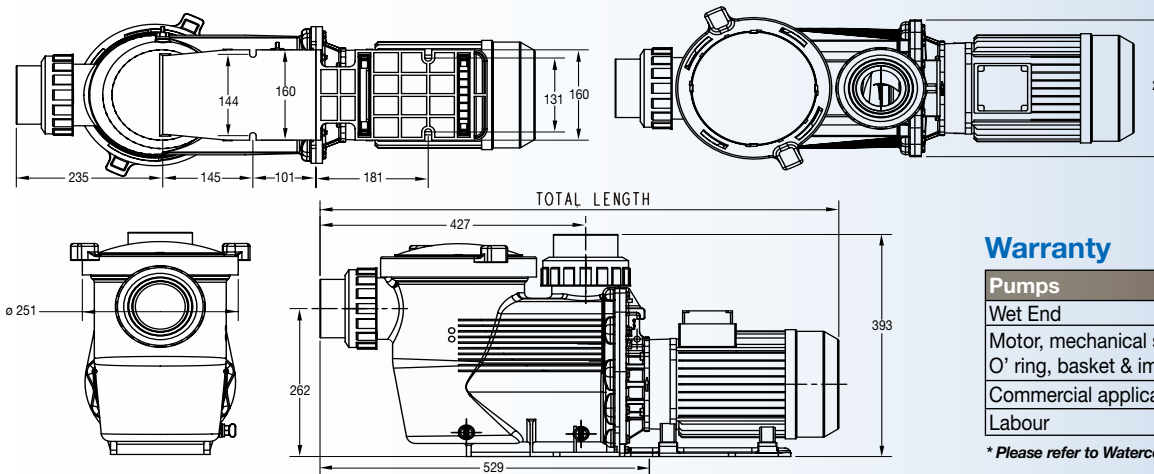

Warranty

Pumps	3 years (conditional) *
Wet End	3 years
Motor, mechanical seal, O' ring, basket & impeller	2 years
Commercial applications	1 year
Labour	1 year

* Please refer to Waterco's warranty terms and conditions



Established since 1981, Waterco is an Australian public listed company involved in the manufacture and distribution of:

- Swimming pool/spa equipment and chemicals
- Domestic water filters, softeners and purifiers
- Commercial and Industrial water treatment equipment.

Waterco's research & development team has created an innovative range of award winning products.

The company's advanced fibreglass winding and pioneering plastic moulding techniques have delivered premium quality products to over 40 countries via its branches operating in Australia, New Zealand, Malaysia, China, the United Kingdom, United States of America, Canada, Indonesia and Singapore.



OFFICES - AUSTRALIA

NSW - Sydney (Head Office)
Tel: +61 2 9898 8600

QLD - Brisbane
Tel: +61 7 3299 9900

VIC/TAS - Melbourne
Tel: +61 3 9764 1211

WA - Perth
Tel: +61 8 9273 1900

SA/NT - Adelaide
Tel: +61 8 8244 6000

ACT Distribution
Tel: +61 2 6280 6476

OFFICES - OVERSEAS

Waterco (Europe) Limited
Sittingbourne, Kent. UK
Tel: +44 (0) 1795 521 733

Waterco (USA) Inc
Augusta, Georgia, USA
Tel: +1 706 793 7291

Waterco Canada
St Hyacinthe, Quebec, Canada
Tel: +1 450 796 1421

Waterco (NZ) Limited
Auckland, New Zealand
Tel: +64 9 525 7570

Waterco (C) Limited
Guangzhou, China
Tel: +86 20 3222 2180

Waterco (Far East) Sdn Bhd
Selangor, Malaysia
Tel: +60 3 6145 6000

PT Waterco Indonesia
Jakarta, Indonesia
Tel: +62 21 4585 1481

Waterco Singapore Intl Pte Ltd
Nehsons Building, Singapore
Tel: +65 6344 2378

DISTRIBUTED BY:

